

※ This document is a temporary specification which does not include whole information about the product.
 ※ This document is subject to be changed for approving product quality without notice.

SPECIFICATIONS	ITEM	LINE FILTER	Rev
	TNC SPEC NO	CH635075SEA	0

1. ELECTRICAL CHARACTERISTIC

NO	ITEM	TERMINAL	SPECIFICATION			REMARKS
1	RATED VOLTAGE	LINE TO LINE	AC 250V			
2	RATED CURRENT	START-FINISH	3.5A			
3	INDUCTANCE	START-FINISH	16KHz	7.5mH	+ 50%, -30%	HP-4194A 1V (25℃±2℃)
4	TEMPERATURE RISE	AT RATED CURRENT	55℃ MAX			
5	DC RESISTANCE	START-FINISH	65.0 mΩ MAX			HIOKI 3540 (25℃±2℃)
6	WITHSTANDING VOLTAGE	LINE TO LINE	AC 1,500V 1 MINUTE.			TOS-5101 CUT OFF CURRENT (0.5mA)
7	INSULATION RESISTANCE	LINE TO COVER	DC 500V, 300MΩ MIN.			TOS-8850

2. OPERATING TEMPERATURE RANGE

-25℃ TO +115℃ INCLUDING TEMPERATURE RISE.

3. KEEP TEMPERATURE RANGE

-10℃ ~ +60℃.

4. CIRCUIT DIAGRAM

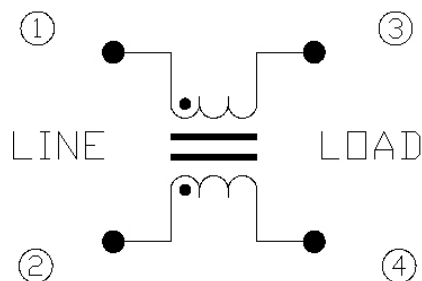

#125 , WOLMUN-RI, PALTAN-MYEON,
 HWASEONG-SI, KYUNGGI-DO, KOREA 445-914
 TEL : 82+(0)313543160
 FAX : 82+(0)313543156

TNC
TNC Co.,LTD

PAGE

1/2

※ This document is a temporary specification which does not include whole information about the product.
 ※ This document is subject to be changed for approving product quality without notice.

SPECIFICATIONS	ITEM	LINE FILTER	Rev
	TNC SPEC NO	CH635075SEA	0

5. WINDING SPECIFICATION

NO	TERMINAL		WIRE	TURNS	WINDING METHOD	UNBALANCE SPECIFICATION
	START	FINISH				
L1	1	3	UEW 0.65Φ	34±2Ts	HANDMADE	BETWEEN L1 AND L2 (0.3mH MAX)
L2	2	4				

6. SHAPE AND DIMENSION

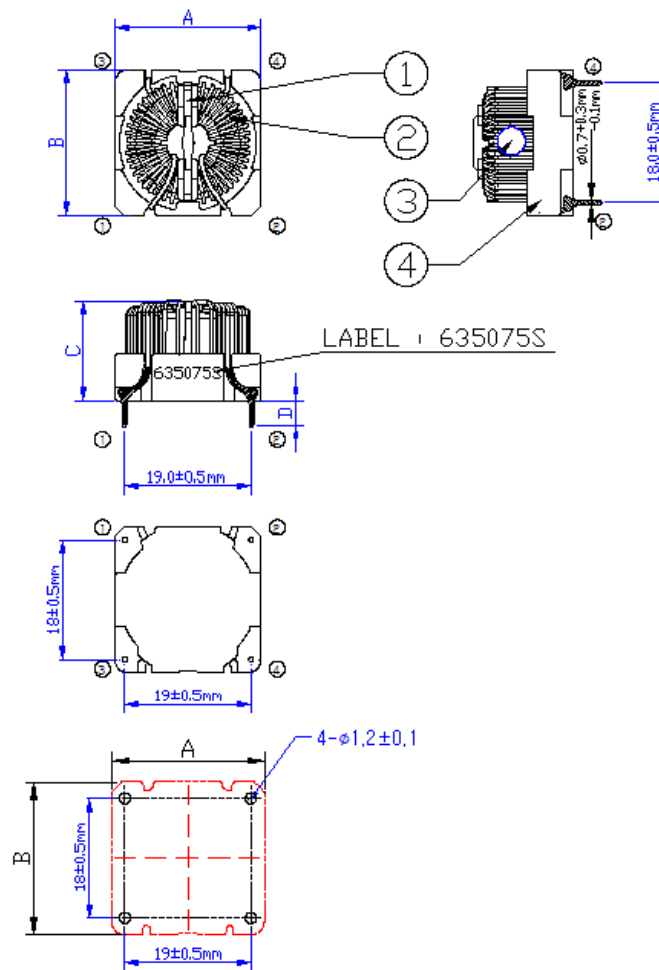

DIMENSION	A	B	C	D
	23.0mm MAX	23.0mm MAX	15.0mm MAX	4.0 ± 1.0mm

#125 , WOLMUN-RI, PALTAN-MYEON,
 HWASEONG-SI, KYUNGGI-DO, KOREA 445-914
 TEL : 82+(0)313543160
 FAX : 82+(0)313543156

TNC
TNC Co.,LTD

PAGE
 2/2