

※ This document is a temporary specification which does not include whole information about the product.
 ※ This document is subject to be changed for approving product quality without notice.

SPECIFICATIONS	ITEM	LINE FILTER	Rev
	TNC SPEC NO	CH540260S	0

1. ELECTRICAL CHARACTERISTIC

NO	ITEM	TERMINAL	SPECIFICATION	REMARKS
1	RATED VOLTAGE	LINE TO LINE	AC 250V	
2	RATED CURRENT	START-FINISH	4.0A	
3	INDUCTANCE	START-FINISH	16KHz 26.0mH + 50%, -30%	HP-4194A 1V (25°C±2°C)
4	TEMPERATURE RISE	AT RATED CURRENT	55°C MAX	
5	DC RESISTANCE	START-FINISH	91.0 mΩ MAX	HIOKI 3540 (25°C±2°C)
6	WITHSTANDING VOLTAGE	LINE TO LINE	AC 1,500V 1 MINUTE.	TOS-5101 CUT OFF CURRENT (5mA)
7	INSULATION RESISTANCE	LINE TO COVER	DC 500V, 300MΩ MIN.	TOS-8850

2. OPERATING TEMPERATURE RANGE

-25°C TO +120°C INCLUDING TEMPERATURE RISE.

3. KEEP TEMPERATURE RANGE

-10°C ~ +60°C.

4. CIRCUIT DIAGRAM

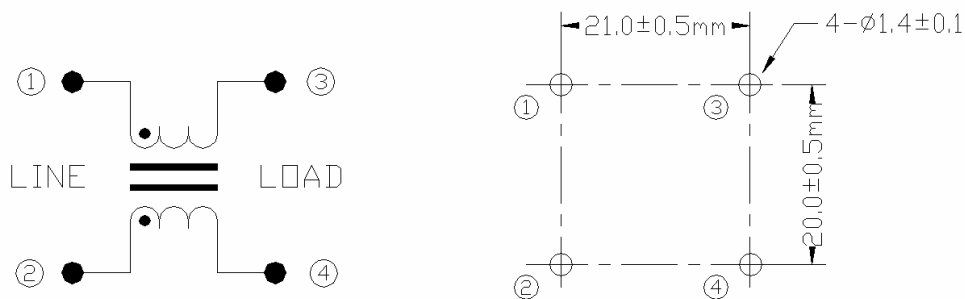

Minimum PCB Piercing HOLE

#125 , WOLMUN-RI, PALTAN-MYEON,
 HWASEONG-SI, KYUNGGI-DO, KOREA 445-914
 TEL : 82+(0)313543160
 FAX : 82+(0)313543156

TNC
TNC Co.,LTD

PAGE
 1/2

※ This document is a temporary specification which does not include whole information about the product.
 ※ This document is subject to be changed for approving product quality without notice.

SPECIFICATIONS	ITEM	LINE FILTER	Rev
	TNC SPEC NO	CH540260S	0

5. WINDING SPECIFICATION

NO	TERMINAL		WIRE	TURNS	WINDING METHOD	UNBALANCE SPECIFICATION
	START	FINISH				
L1	1	3	UEW 0.8Φ	46 ±2Ts	HANDMADE	BETWEEN L1 AND L2 (1.2mH MAX)
L2	2	4				

6. SHAPE AND DIMENSION

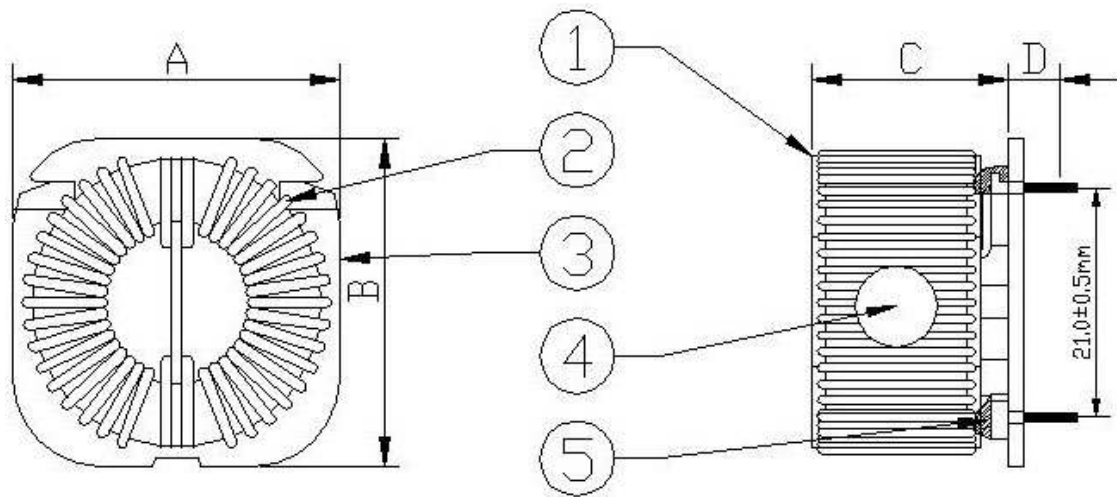

MARKING: CH540260S

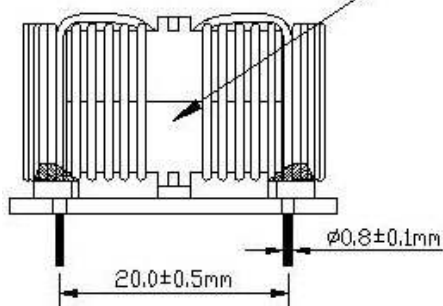

DIMENSION	A	B	C	D
	35.0mm MAX	35.0mm MAX	25.0mm MAX	4.0±1.0mm

#125 , WOLMUN-RI, PALTAN-MYEON,
 HWASEONG-SI, KYUNGGI-DO, KOREA 445-914
 TEL : 82+(0)313543160
 FAX : 82+(0)313543156

TNC
TNC Co.,LTD

PAGE

2/2