

※ This document is a temporary specification which does not include whole information about the product.  
 ※ This document is subject to be changed for approving product quality without notice.

SPECIFICATIONS	ITEM	LINE FILTER	Rev
	TNC SPEC NO	CH112045	0

## 1. ELECTRICAL CHARACTERISTIC

NO	ITEM	TERMINAL	SPECIFICATION			REMARKS
1	RATED VOLTAGE	LINE TO LINE	AC 250V			
2	RATED CURRENT	START-FINISH	20.0A			
3	INDUCTANCE	START-FINISH	16KHz	4.5mH	+ 50%, -30%	HP-4194A 1V (25°C±2°C)
4	TEMPERATURE RISE	AT RATED CURRENT	55°C MAX			
5	DC RESISTANCE	START-FINISH	17.0 mΩ MAX			HIOKI 3540 (25°C±2°C)
6	WITHSTANDING VOLTAGE	LINE TO LINE	AC 1,500V 1 MINUTE.			TOS-5101 CUT OFF CURRENT (5mA)
7	INSULATION RESISTANCE	LINE TO COVER	DC 500V, 300MΩ MIN.			TOS-8850

## 2. OPERATING TEMPERATURE RANGE

-25°C TO +120°C INCLUDING TEMPERATURE RISE.

## 3. KEEP TEMPERATURE RANGE

-10°C ~ +60°C.

## 4. CIRCUIT DIAGRAM

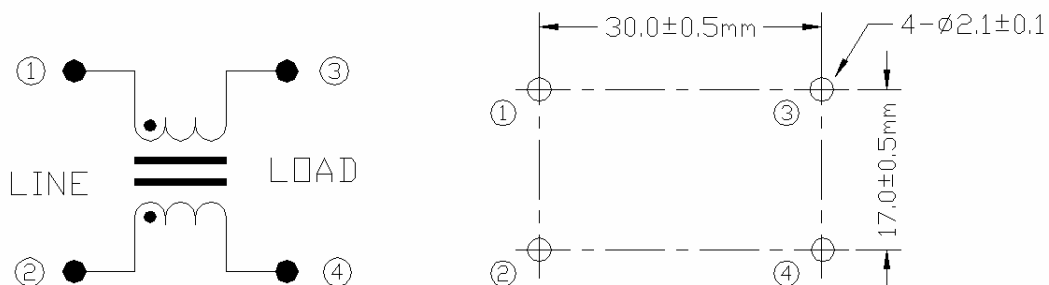

Minimum PCB piercing plan

#125 , WOLMUN-RI, PALTAN-MYEON,  
 HWASEONG-SI, KYUNGGI-DO, KOREA 445-914  
 TEL : 82+(0)313543160  
 FAX : 82+(0)313543156

**TNC**  
**TNC Co.,LTD**

PAGE

1/2

※ This document is a temporary specification which does not include whole information about the product.  
 ※ This document is subject to be changed for approving product quality without notice.

SPECIFICATIONS	ITEM	LINE FILTER	Rev
	TNC SPEC NO	CH112045	0

### 5. WINDING SPECIFICATION

NO	TERMINAL		WIRE	TURNS	WINDING METHOD	UNBALANCE SPECIFICATION
	START	FINISH				
L1	1	3	PEW 1.5Φ	24 ±1Ts	HANDMADE	BETWEEN L1 AND L2 (0.4mH MAX)
L2	2	4				

### 6. SHAPE AND DIMENSION

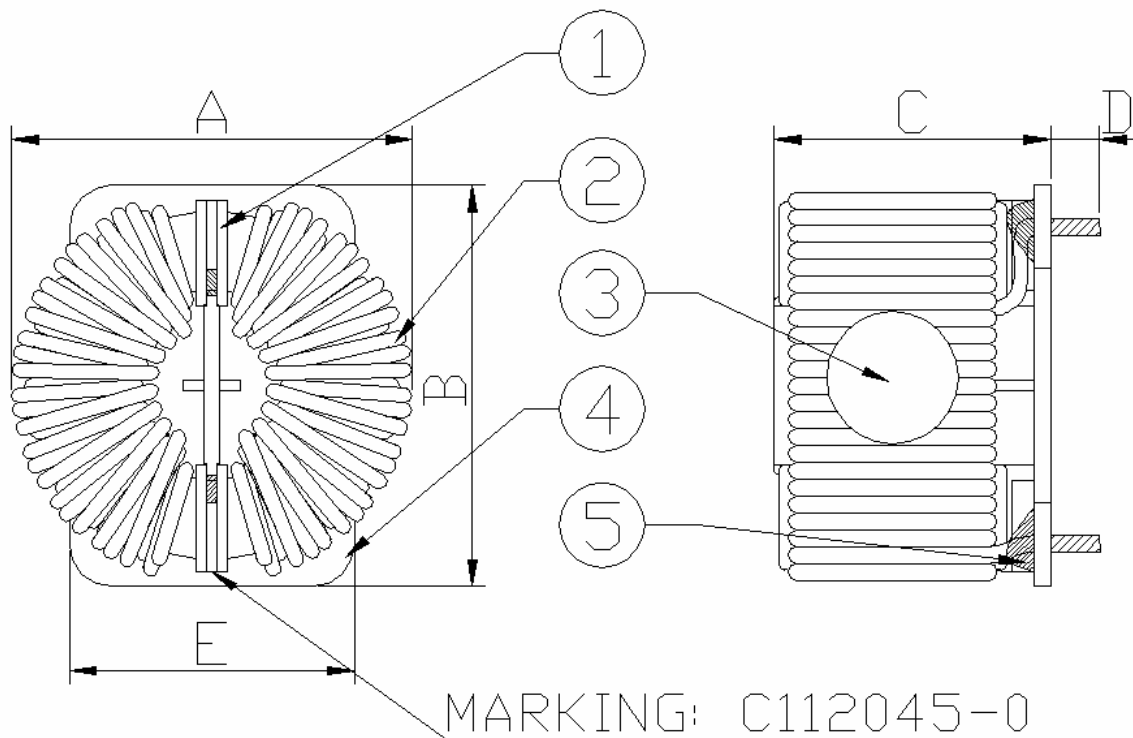

DIMENSION	A	B	C	D
		42.0mm MAX	40.0mm MAX	30.0mm MAX

#125 , WOLMUN-RI, PALTAN-MYEON,  
 HWASEONG-SI, KYUNGGI-DO, KOREA 445-914  
 TEL : 82+(0)313543160  
 FAX : 82+(0)313543156

**TNC**  
**TNC Co.,LTD**

PAGE

2/2