

※ This document is a temporary specification which does not include whole information about the product.  
 ※ This document is subject to be changed for approving product quality without notice.

SPECIFICATIONS	ITEM	LINE FILTER	Rev
	TNC SPEC NO	CS3170065MB01	0

## 1. ELECTRICAL CHARACTERISTIC

NO	ITEM	TERMINAL	SPECIFICATION	REMARKS
1	RATED VOLTAGE	LINE TO LINE	AC 250V	
2	RATED CURRENT	START-FINISH	7.0A	
3	INDUCTANCE	START-FINISH	16KHz 6.5mH +50%,-30%	HP-4194A 1V (25°C±2°C)
4	TEMPERATURE RISE	AT RATED CURRENT	55°C MAX	
5	DC RESISTANCE	START-FINISH	26.0 mΩ MAX	HIOKI 3540 (25°C±2°C)
6	WITHSTANDING VOLTAGE	LINE TO LINE	AC 1,500V 1 MINUTE.	TOS-5101 CUT OFF CURRENT (5mA)
7	INSULATION RESISTANCE	LINE TO COVER	DC 500V, 300MΩ MIN.	TOS-8850

## 2. OPERATING TEMPERATURE RANGE

-25°C TO +115°C INCLUDING TEMPERATURE RISE.

## 3. KEEP TEMPERATURE RANGE

-10°C ~ +60°C.

## 4. CIRCUIT DIAGRAM

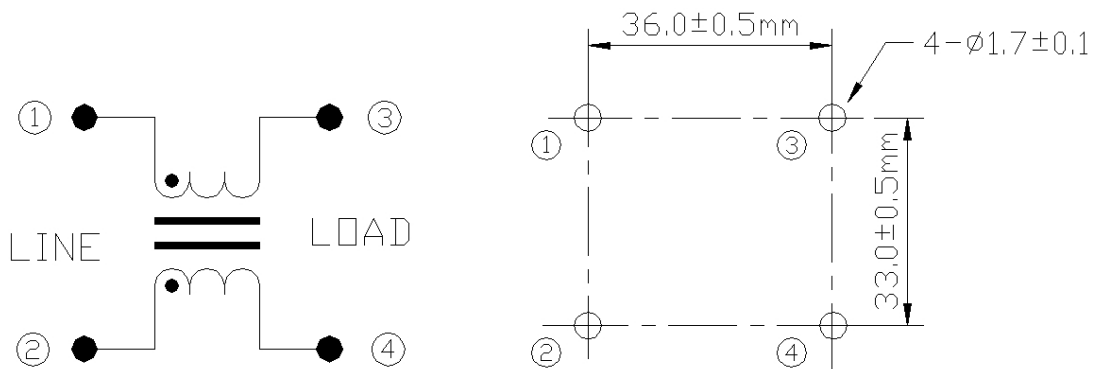

Minimum PCB piercing plan

#125 , WOLMUN-RI, PALTAN-MYEON,  
 HWASEONG-SI, KYUNGGI-DO, KOREA 445-914  
 TEL : 82+(0)313543160  
 FAX : 82+(0)313543156

**TNC**  
**TNC Co.,LTD**

PAGE

1/2

※ This document is a temporary specification which does not include whole information about the product.  
 ※ This document is subject to be changed for approving product quality without notice.

SPECIFICATIONS	ITEM	LINE FILTER	Rev
	TNC SPEC NO	CS3170065MB01	0

### 5. WINDING SPECIFICATION

NO	TERMINAL		WIRE	TURNS	WINDING METHOD	UNBALANCE SPECIFICATION
	START	FINISH				
L1	1	3	PEW 1.2Φ	36 ±2Ts	HANDMADE	BETWEEN L1 AND L2 (0.4mH MAX)
L2	2	4				

### 6. SHAPE AND DIMENSION

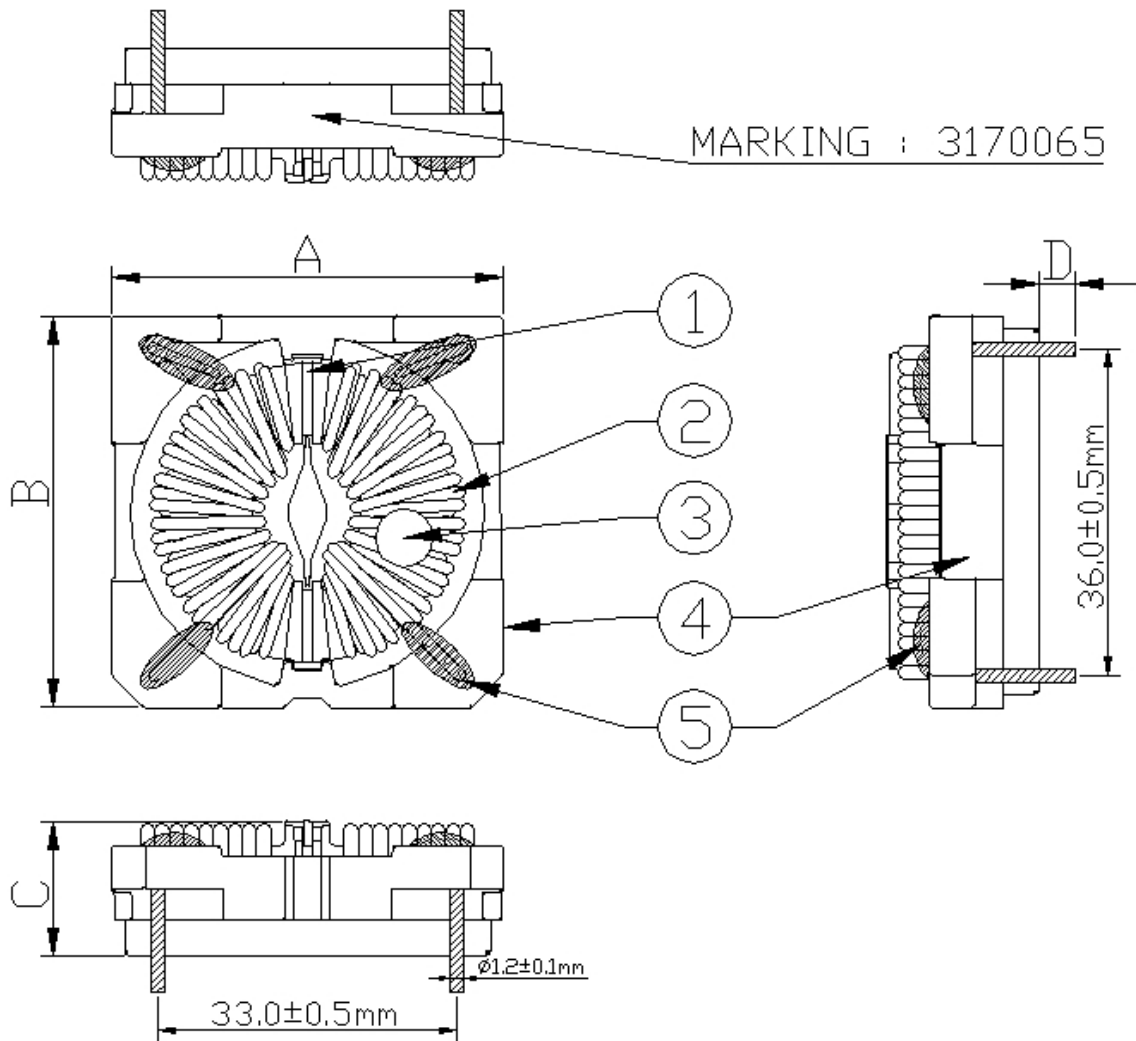

DIMENSION	A	B	C	D
	45.0mm MAX	45.0mm MAX	16.0mm MAX	4.0±1.0mm

#125 , WOLMUN-RI, PALTAN-MYEON,  
 HWASEONG-SI, KYUNGGI-DO, KOREA 445-914  
 TEL : 82+(0)313543160  
 FAX : 82+(0)313543156

**TNC**  
**TNC Co.,LTD**

PAGE  
 2/2